

**OPERATED VERTICAL LIFT HERCULES™ DOOR  
MODEL EVL  
INSTALLATION INSTRUCTIONS**

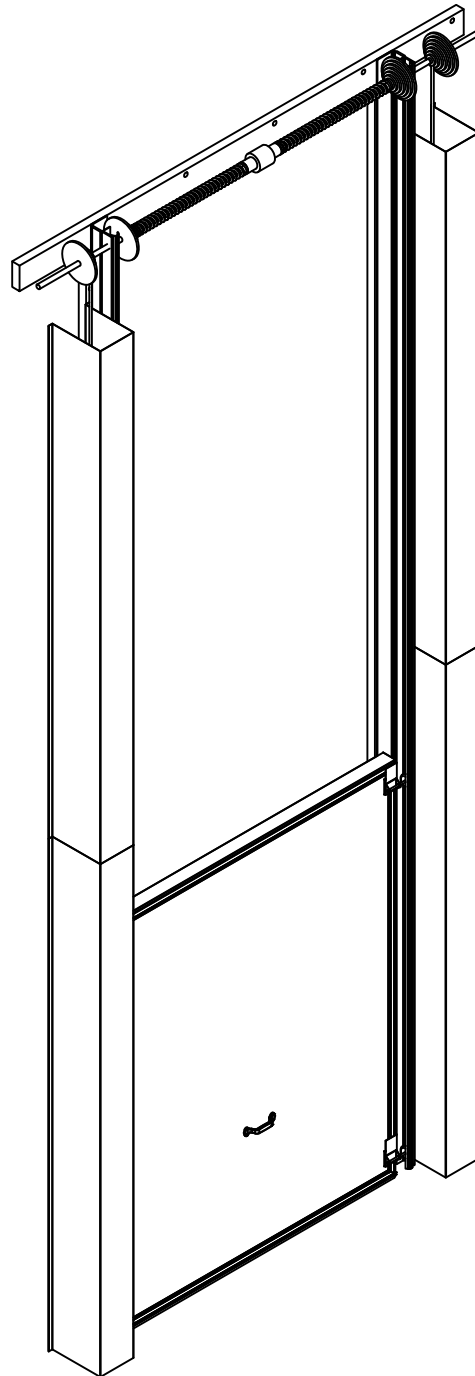

**HERCULES**

A SENNECA COMPANY

1	1.1 Notice to Installer & Door Specification . . . . .	3
	1.2 Installation tool requirements . . . . .	4
2	Installation	
	2.1 Installing vertical casing (w/track) . . . . .	5
	Installing vertical casing (w/track) continued . . . . .	6
	2.2 Installing seal header assembly . . . . .	7
	2.3 Installing opener assist header assembly . . . . .	8
	2.4 Installing door . . . . .	9
	2.5 Installing roller shim/collar . . . . .	10
	2.6 Installing counter weight & adjustment . . . . .	11
	2.7 Installing torsion spring adjustment . . . . .	12
3	Electrical Connections	
	3.1 Electrical connections—Door junction box . . . . .	13
	3.2 Electrical connections—Electric operator . . . . .	14
4	Finishing	
	4.1 Final adjustments & clean-up . . . . .	15

**HERCULES**

A SENNECA COMPANY

**HERCULES**  
**COLD STORAGE DOORS**  
**INSTALLATION INSTRUCTIONS**

DRAWN BY: DSD    DATE: 6/16/09

**1.1 Notice to installer**  
**(Please read this notice before attempting installation)**

Hercules Doors are high quality products that are time tested to function properly if installed in accordance with the installation instructions. It is in the installer's best interest that the doors be installed properly. Please read and follow the installation instructions carefully to avoid costly time on the job correcting installation mistakes. Hercules warrants our products for defects in material and workmanship only. Since the installation of our products is beyond our control, Hercules does not warranty labor.

It is the responsibility of the installer to make sure that the mounting structure (walls) to which the door is to be attached is straight, level, and on the same plane with each other around the door opening as well as the floor surface. If these conditions cannot be met, the vertical casings and header must be shimmed to ensure that the door, when properly adjusted, will provide the proper sealing required. The floor must be flat, level, and in good condition for the bottom seal to be effective.

**Warning!**

Only qualified and experienced cold storage door installers and electricians should attempt to install or service this product. Installation by non-qualified personnel may result in serious injury during the installation process or during actual operation and in the use of this door.

**Avertissement!**

Seulement du personnel qualifié devrait faire l'installation de cette porte. L'installation fait par du personnel non-qualifié, peut entraîner des blessures graves durant l'installation et / ou l'utilisation de la porte.

**Please Note!**

**(Heater Voltage is 115 V AC For Freezer Doors)**

**VEUILLEZ NOTER!**

**Voltage du câble chauffant est 120 V AC pour les portes de congélateurs**

Hercules Doors may be reached at: 1-800-543-4455 if assistance is required.

Door Specifications:

Size: Width in clear in inches (W.I.C.) =

Door serial #

Height in clear in inches (H.I.C.) =

Note: If door is a thru-wall model, rough opening will need to be 3/4" wider than the W.I.C. and 1 5/8" taller than the H.I.C.

Door Model: EVL    Thru-wall:  Yes     No

Wall Thickness:

Opening Direction: VERTICAL

Door Style:  Freezer     Cooler

Door Heater (Freezer Doors Only):  115 Volts AC  Watts

Door Type: ELECTRIC

Door Operator Voltage:

Door Activation Devices:

**DOOR HEATER VOLTAGE APPLIES  
TO FREEZER DOORS ONLY!  
COOLER DOORS DO NOT HAVE  
HEATER WIRES!**

# **HERCULES** **COLD STORAGE DOORS** **INSTALLATION INSTRUCTIONS**

DRAWN BY: DSD    DATE: 6/16/09

## **1.2 These are the tools that might be required for installation**

**1.2 Ce sont les outils qui pourraient être requis pour l'installation**



**PRYBAR**



**C-CLAMP**



**COMBINATION  
WRENCHES**



**HAMMER**

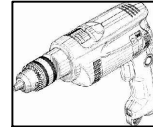

**ELECTRIC  
DRILL**



**WISE  
GRIPS**

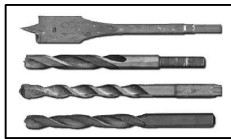

**DRILL BIT  
SET**



**HAMMER  
DRILL**



**LEVEL**



**RUBBER  
MALLET**



**MEASURING  
TAPE**



**UTILITY  
KNIFE**



**TIN  
SNIPS/SCISSORS**



**CAULKING  
GUN**



**SHIMS**



**LADDER**

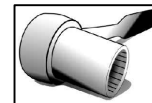

**SOCKET  
WRENCH  
SET**



**SCREWDRIVER  
SET**



**BUTYL CAULK**



**LIFTING  
EQUIPMENT MAY  
BE REQUIRED  
DEPENDING ON  
DOOR SIZE**

**HERCULES**  
**COLD STORAGE DOORS**  
**INSTALLATION INSTRUCTIONS**

DRAWN BY: DSD

DATE: 6/16/09

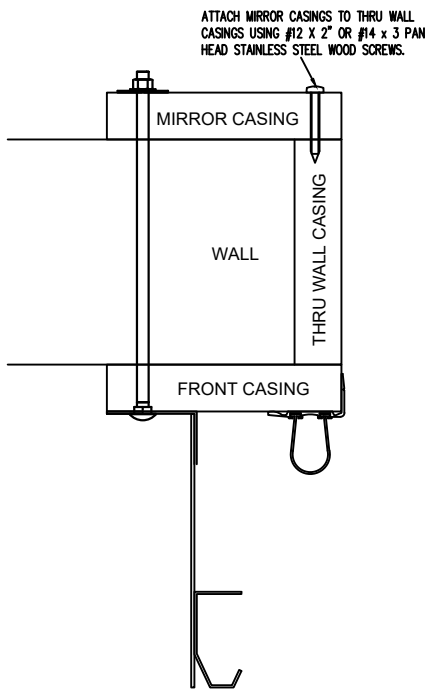

**SECTION A-A**

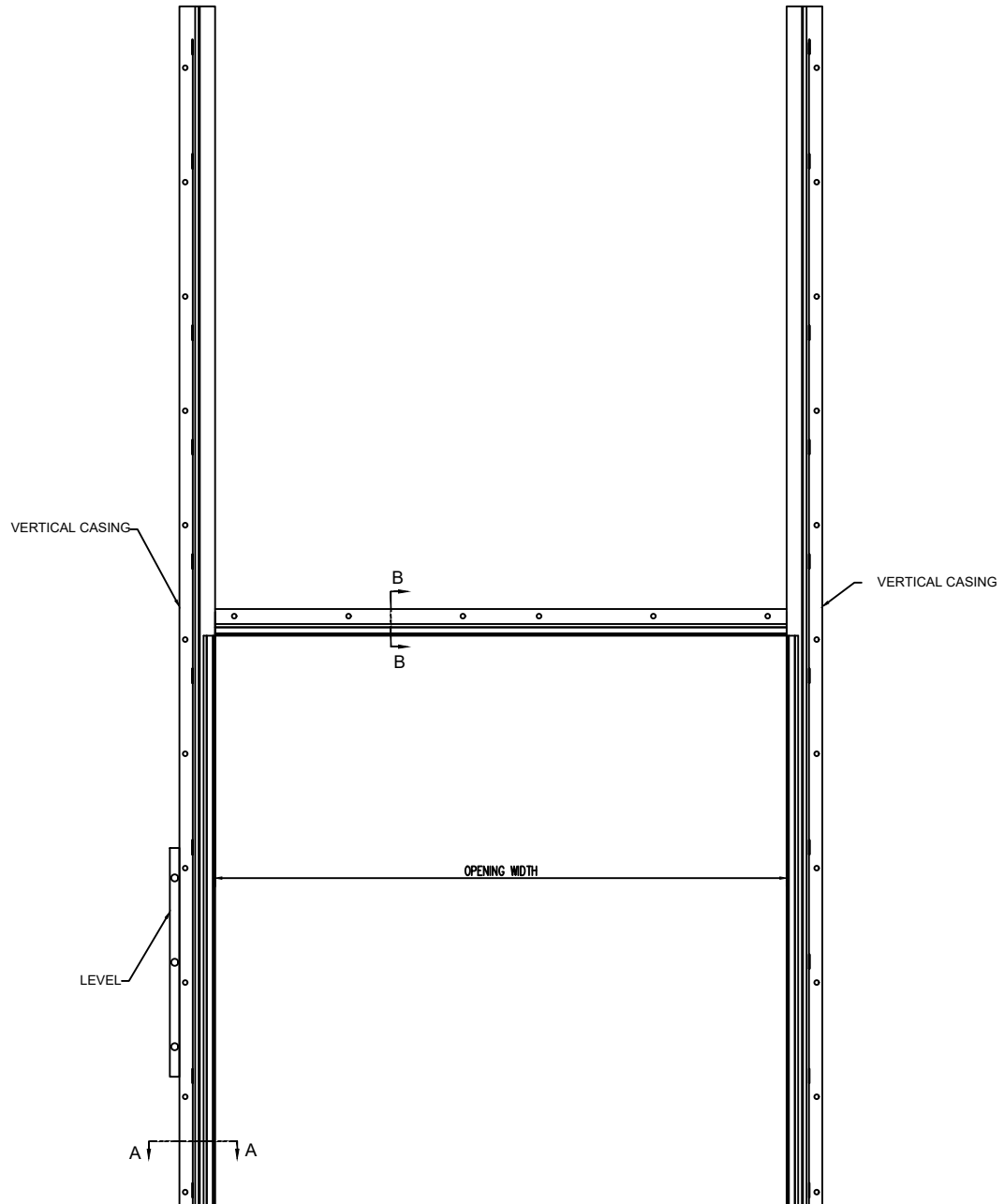

**2.1 VERTICAL CASING (W/ TRACK) INSTALLATION**

**STEP - 1. PREPARATION:**

MEASURE WIDTH AND HEIGHT OF FRAMED OPENING AND COMPARE WITH DIMENSIONS GIVEN AT TIME OF ORDERING.

**STEP - 2.**

BUTYL CAULK (BY OTHERS) IS RECOMMENDED AND SHOULD BE APPLIED TO WALL SIDE OF CASINGS BEFORE INSTALLATION.

**STEP - 3.**

STAND ONE VERTICAL CASING UP TO THE WALL ALONG AN EDGE OF DOOR OPENING.

**STEP - 4.**

USING A LEVEL, MAKE SURE THE CASING IS STRAIGHT AND PLUMB.

**STEP - 5.**

IF BOTTOM OF CASING IS LOWER THAN HIGH POINT IN FLOOR, SHIM UNDER BOTTOM OF CASING SO THAT IT IS LEVEL WITH HIGH POINT IN FLOOR. THEN TEMPORARILY CLAMP OR LAG THE CASING TO THE WALL.

**HERCULES**  
**COLD STORAGE DOORS**  
**INSTALLATION INSTRUCTIONS**

DRAWN BY: DFS

DATE: 6/16/09

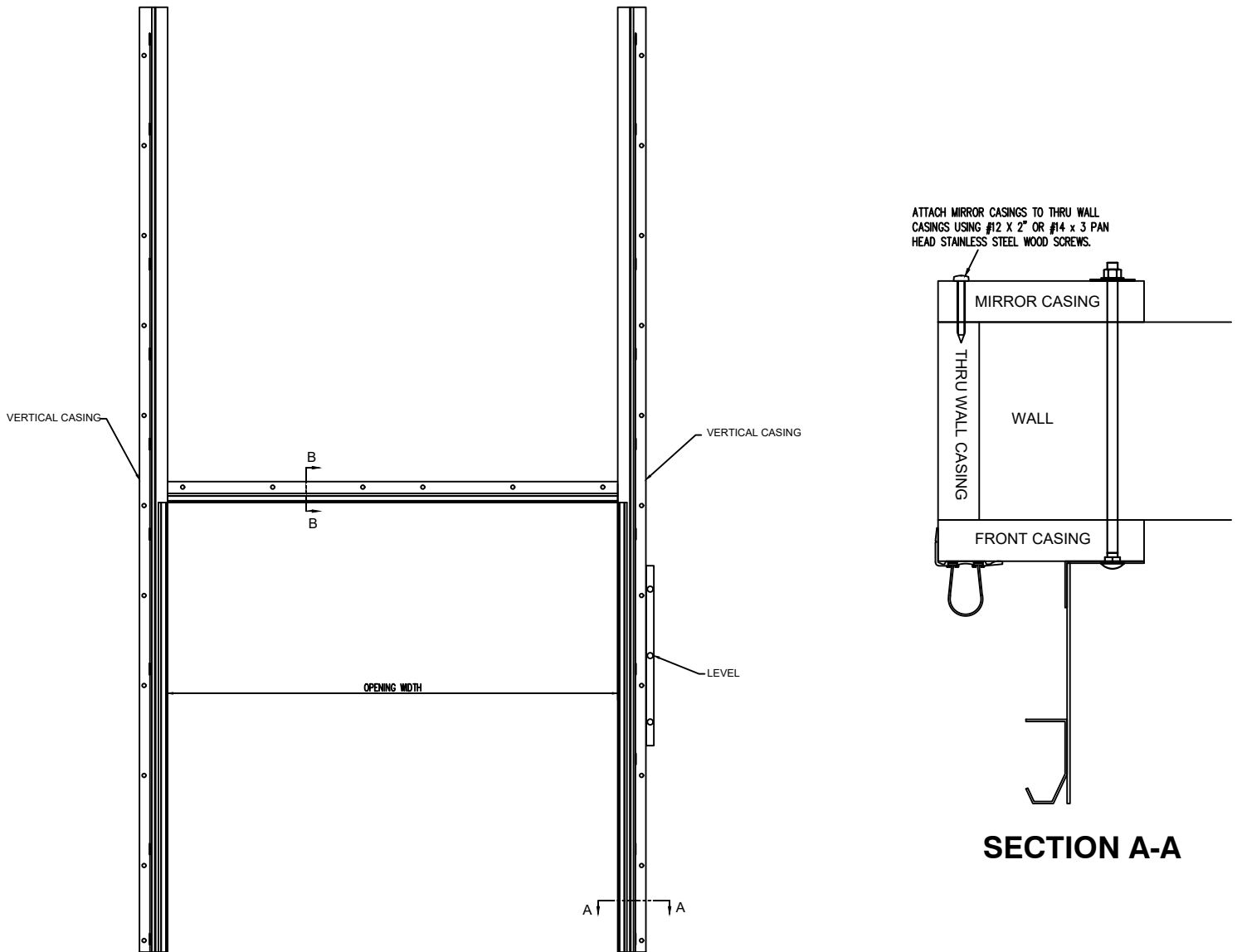

**VERTICAL CASING (W/ TRACK) INSTALLATION CONTINUED**

**STEP - 6.**

- a) STAND THE OTHER VERTICAL CASING UP TO THE WALL ALONG THE OTHER EDGE OF DOOR OPENING.
- b) ADJUST THE CASING TO BE THE SPECIFIED WIDTH IN CLEAR OF THE DOOR OPENING AS SPECIFIED ON PAGE 2 OF THESE INSTRUCTIONS.
- c) THIS CASING MAY HAVE TO BE ADJUSTED SLIGHTLY WHEN THE HEADER IS INSTALLED SO AS TO ALIGN WITH HOLES IN HEADER FOR LOCATOR PINS (NOT ON THRU-WALL JAMBS MODEL).

**STEP - 7.**

USING A LEVEL, MAKE SURE THE CASING IS STRAIGHT AND PLUMB. ALSO CHECK TOP OF CASINGS WITH STRING, WATER, OR LASER LEVEL TO MAKE SURE THEY ARE LEVEL.

**STEP - 8.**

IF BOTTOM OF CASING IS LOWER THAN HIGH POINT IN FLOOR, SHIM UNDER BOTTOM OF CASING SO THAT IT IS LEVEL WITH HIGH POINT IN FLOOR. THEN TEMPORARILY CLAMP OR LAG THE CASING TO THE WALL.

**HERCULES**  
**COLD STORAGE DOORS**  
**INSTALLATION INSTRUCTIONS**

DRAWN BY: DSD

DATE: 6/16/09

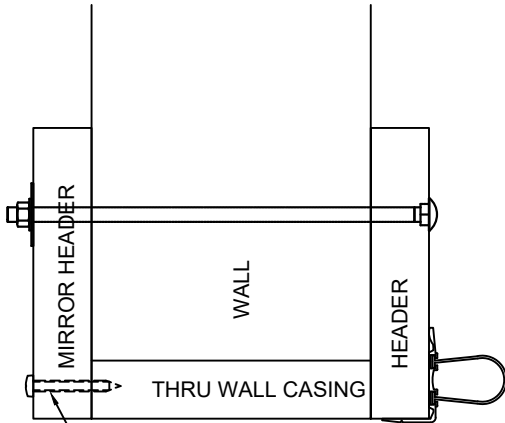

ATTACH MIRROR CASINGS TO THRU WALL CASINGS USING #12 X 2" OR #14 X 3 PAN HEAD STAINLESS STEEL WOOD SCREWS.

**SECTION B-B**

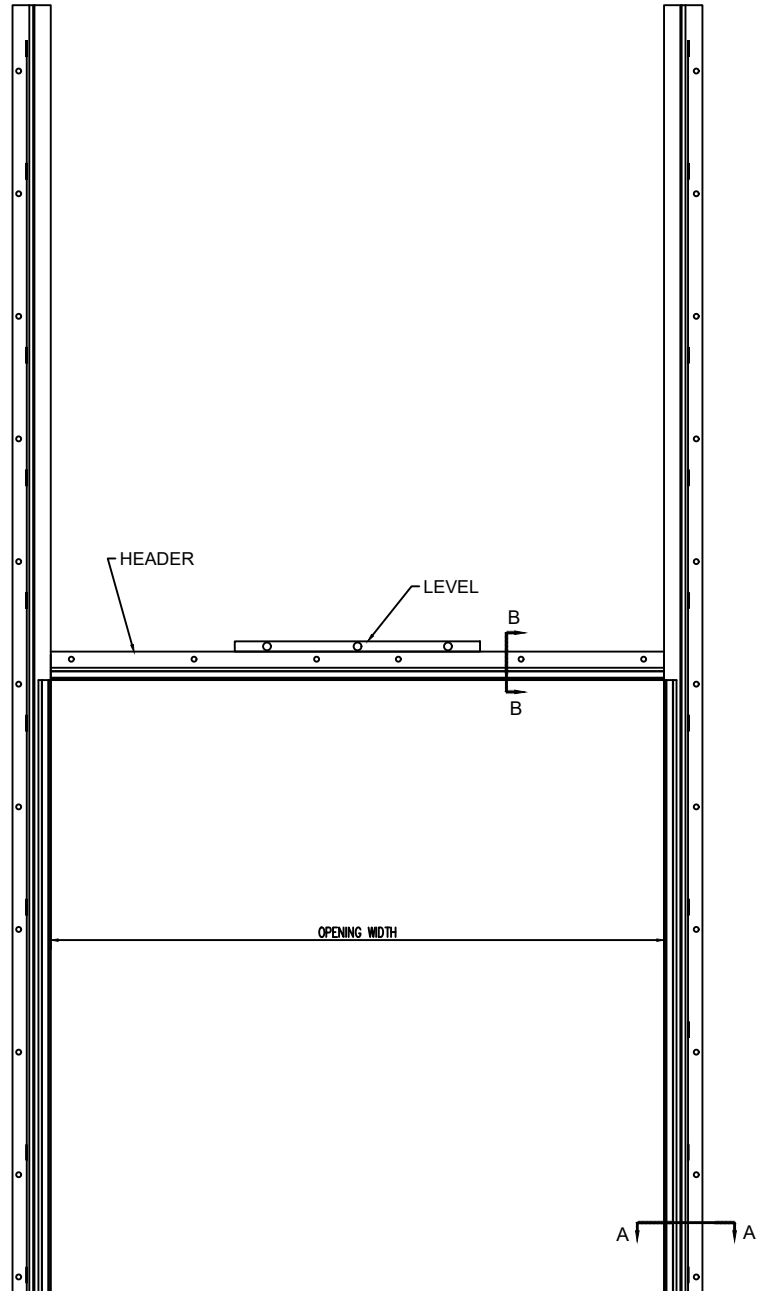

**2.2 SEAL HEADER ASSEMBLY**

**STEP - 1.**

- a) USING PROPER METHOD OF LIFTING THE SEAL HEADER, RAISE HEADER ABOVE THE CASINGS AND LOWER IT DOWN TO THE EDGE OF THE OPENING.
- b) AT THIS POINT IT MAY BE NECESSARY TO ADJUST THE POSITION OF THE VERTICAL CASING SLIGHTLY TO FIT THE SEAL HEADER.

**STEP - 2.**

BUTYL CAULK (BY OTHERS) IS RECOMMENDED AND SHOULD BE APPLIED TO WALL SIDE OF CASINGS BEFORE INSTALLATION.

**STEP - 3.**

- a) USING A LEVEL, CHECK TO MAKE SURE SEAL HEADER IS LEVEL, STRAIGHT AND TRUE.

**STEP - 4.**

- a) DRILL A 3/8" HOLE THROUGH THE PRE-DILLED HOLES IN THE SEAL HEADER, AND THROUGH THE WALL OR BOX.
- b) USING THE CARRIAGE BOLTS, NUTS, WASHERS, AND FENDER WASHERS SUPPLIED IN THE HARDWARE PARTS BOX, INSERT THE BOLTS & TIGHTEN. DO NOT CUT OFF BOLTS AT THIS TIME.
- c) CARRIAGE BOLT HEADS SHOULD BE INSTALLED ON DOOR SIDE OF WALL. NUTS AND WASHERS SHOULD BE USED ON OPPOSITE SIDE OF WALL FROM DOOR.

# HERCULES COLD STORAGE DOORS INSTALLATION INSTRUCTIONS

DRAWN BY: DSD

DATE: 6/16/09

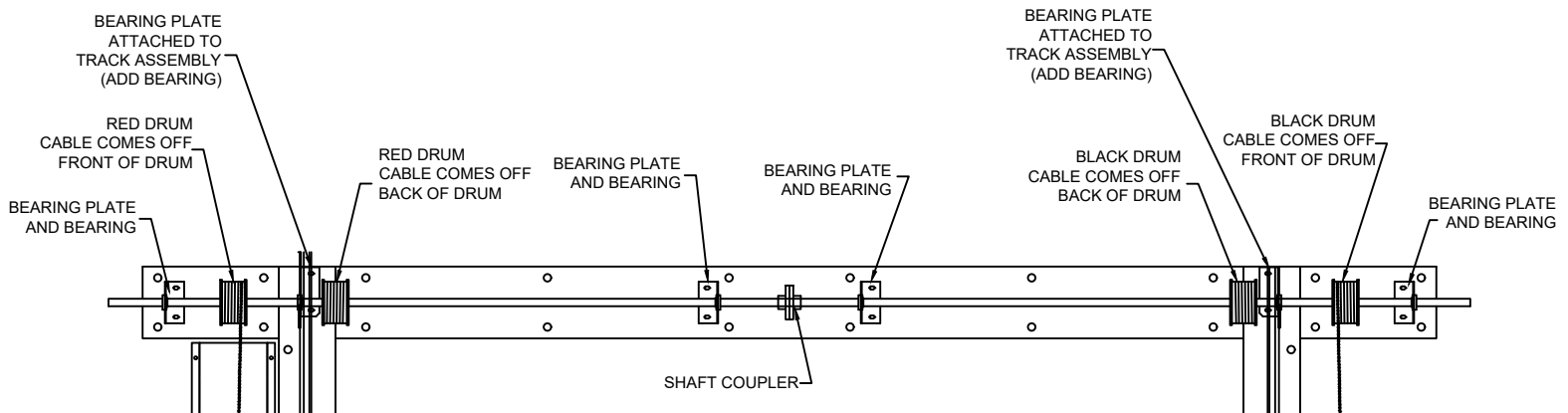
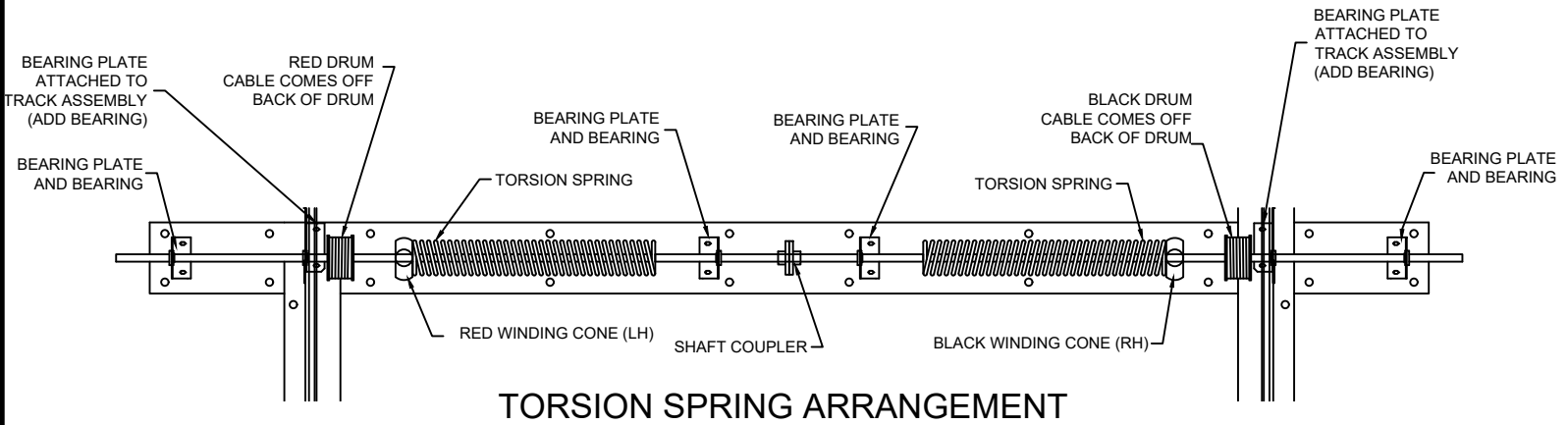

## 2.3 OPENER ASSIST HEADER ASSEMBLY

### STEP - 1.

- a) USING PROPER METHOD OF LIFTING THE OPENER ASSIST HEADER, RAISE AND ALIGN HEADER AND EXTENSIONS FLUSH WITH THE TOPS OF THE VERTICAL CASINGS.
- b) ASSEMBLE  $\varnothing 1$ " SHAFTS THRU BEARING PLATES INSERTING BEARINGS, CABLE DRUMS, AND TORSION SPRINGS WITH RETAINERS (IF INCLUDED) AS SHOWN. USE CAUTION WHEN INSTALLING WINDING CONES AND SPRINGS AS THEY CAN CAUSE INJURY.

### STEP - 2.

BUTYL CAULK (BY OTHERS) IS RECOMMENDED AND SHOULD BE APPLIED TO WALL SIDE OF CASINGS BEFORE INSTALLATION.

### STEP - 3.

- a) LEVEL THE  $\varnothing 1$ " SHAFTS PRIOR TO TIGHTENING BEARINGS TO BEARING PLATES.

### STEP - 4.

- a) DRILL A  $\frac{3}{8}$ " HOLE THROUGH THE PRE-DILLED HOLES IN THE OPENER ASSIST HEADER, AND THROUGH THE WALL OR BOX.
- b) USING THE CARRIAGE BOLTS, NUTS, WASHERS, AND FENDER WASHERS SUPPLIED IN THE HARDWARE PARTS BOX, INSERT THE BOLTS & TIGHTEN. DO NOT CUT OFF BOLTS AT THIS TIME.
- c) CARRIAGE BOLT HEADS SHOULD BE INSTALLED ON DOOR SIDE OF WALL. NUTS AND WASHERS SHOULD BE USED ON OPPOSITE SIDE OF WALL FROM DOOR.

# HERCULES COLD STORAGE DOORS INSTALLATION INSTRUCTIONS

DRAWN BY: DSD

DATE: 6/16/09

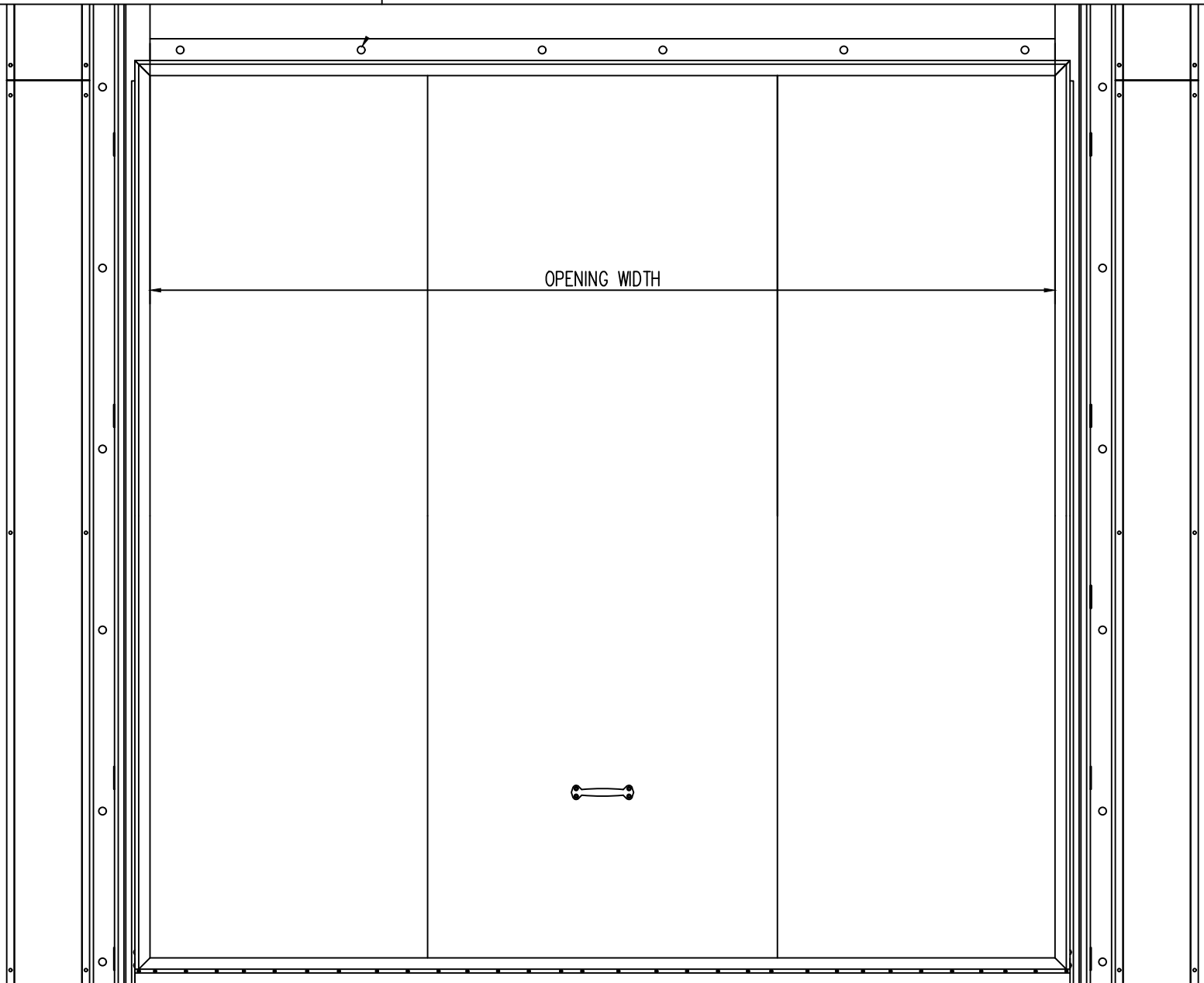

## 2.4 DOOR INSTALLATION

### STEP - 1.

- REMOVE TOP AND BOTTOM ROLLER BRACKETS
- POSITION DOOR UPRIGHT IN THE OPENING BETWEEN THE RAILS.
- PLACE A ROLLER IN THE TRACK AND SLIDE STEM THROUGH THE BRACKET AND ATTACH TO DOOR. REPEAT UNTIL ALL BRACKETS ARE SECURED.

### STEP - 2.

- ATTACH THE LIFT CABLE FROM THE BOTTOM BRACKETS TO THE DRUMS.
- ALIGN THE DRUMS ALLOWING THE CABLES TO RUN STRAIGHT TO THE BRACKETS. TIGHTEN THE DRUM TO THE Ø1" SHAFT. DRUM MAY NEED READJUSTMENT LATER.

### STEP - 3.

- ADJUST THE TRACK SYSTEM AND TOP ROLLERS TO PROVIDE  $\frac{1}{8}$ " TO  $\frac{1}{4}$ " COMPRESSION OF THE TRACK MOUNTED DOOR SEAL.
- ADJUST CLOSING ASSIST DEVICE (COUNTER WEIGHT [SH 10] OR TORSION SPRING [SH 11]) TO OBTAIN SMOOTH AND EASY LIFT AND CLOSE OF THE DOOR.
- INSTALL SHIM BEHIND UPPER ROLLERS AND LOWER ROLLERS AND COLLAR ON ALL ROLLER SHAFTS (SH 9)

**HERCULES**  
**COLD STORAGE DOORS**  
**INSTALLATION INSTRUCTIONS**

DRAWN BY: DSD

DATE: 6/16/09

USE SHIM #S18966 BEHIND UPPER ROLLERS  
USE SHIM #S18967 BEHIND LOWER ROLLERS  
(ALL FOUR CORNERS OF DOOR)  
Shims required and provided  
only on doors with trim caps

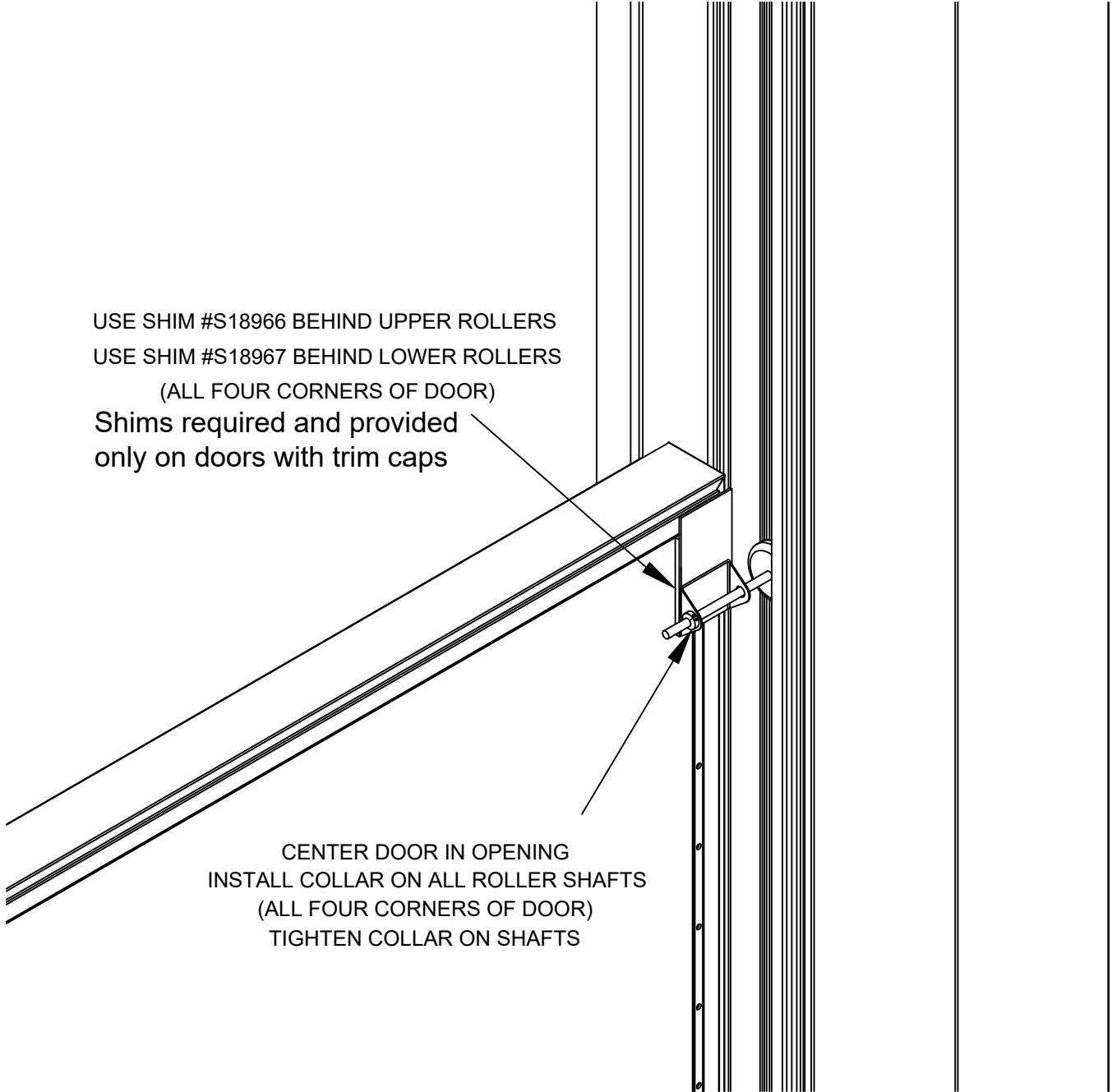

CENTER DOOR IN OPENING  
INSTALL COLLAR ON ALL ROLLER SHAFTS  
(ALL FOUR CORNERS OF DOOR)  
TIGHTEN COLLAR ON SHAFTS

**2.5 ROLLER SHIM/COLLAR INSTRUCTIONS**

# HERCULES COLD STORAGE DOORS INSTALLATION INSTRUCTIONS

DRAWN BY: DSD

DATE: 6/16/09

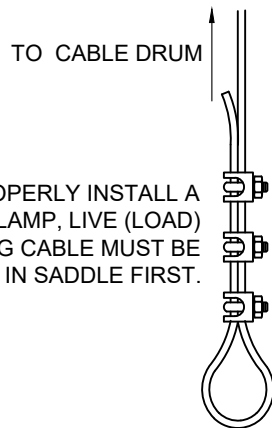

**DETAIL A**

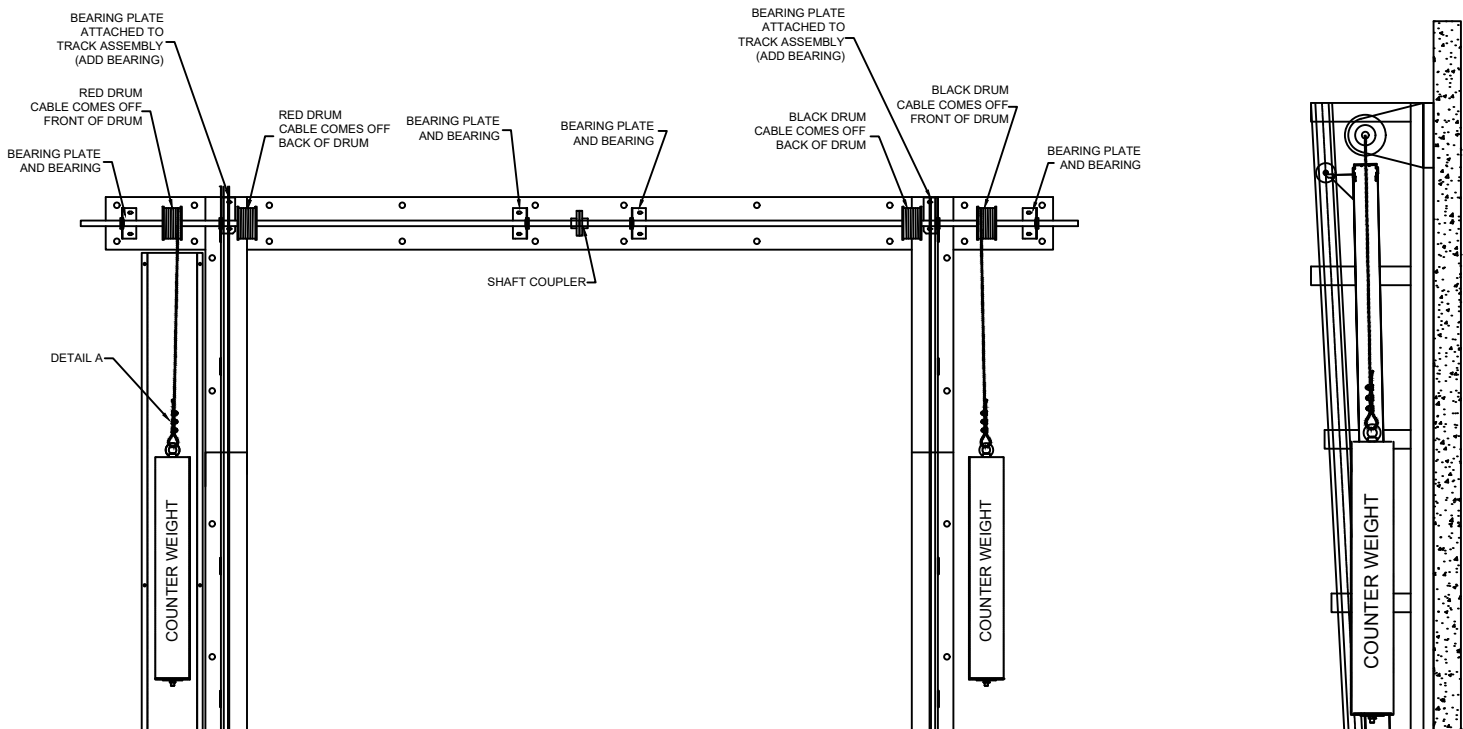

## 2.6 COUNTER WEIGHT INSTALLATION & ADJUSTMENT

**STEP - 1. (SEE DETAIL - A)**

ATTACH THE CABLE FROM THE OUTER DRUM TO THE COUNTER WEIGHT AS SHOWN.

- a) FILL WEIGHT HOLDERS SLOWLY ALTERNATING BETWEEN LEFT AND RIGHT HOLDERS.
- b) FILL HOLDERS UNTIL DOOR IS BALANCED. IF PROPERLY BALANCED THE DOOR SHOULD REMAIN IN ANY POSITION PLACED WITHOUT MOVING UP OR DOWN.
- c) FOR BEST OPERATION, WEIGHT HOLDERS SHOULD HAVE EQUAL WEIGHTS WHEN FILLED.

**STEP - 3.**

AFTER RE-TIGHTENING ALL CABLE CLAMPS, INSTALL WEIGHT COVER WITH 3/8" X 12" THREADED ROD, NUTS, WASHERS, AND FENDER WASHERS (SUPPLIED WITH HARDWARE).

# HERCULES COLD STORAGE DOORS INSTALLATION INSTRUCTIONS

DRAWN BY: DSD

DATE: 6/16/09

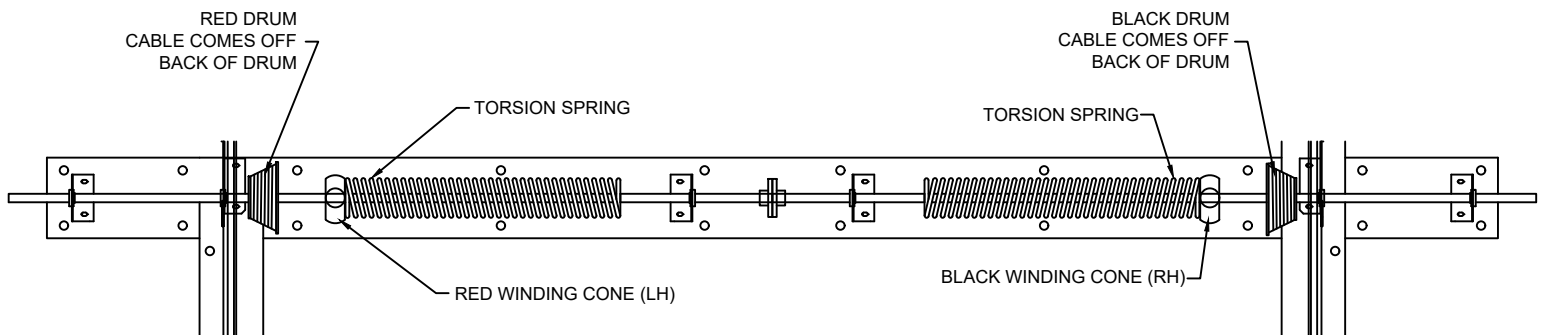

## IMPORTANT SAFETY INFORMATION

TORSION SPRINGS CAN BE DANGEROUS IF IMPROPERLY INSTALLED OR HANDLED.

### 2.7 TORSION SPRING ADJUSTMENT

#### STEP - 1.

- DOOR MUST BE IN FULLY CLOSED POSITION TO COMPLETE ADJUSTMENT. SECURE DOOR CLOSED WITH A C-CLAMP PLACED ON THE GARAGE DOOR TRACK ABOVE THE LOWEST ROLLER.
- WITH TWO (2) METAL BARS (NOT INCLUDED) INSERTED IN PERIMETER HOLES OF THE WINDING CONE, THE SET SCREW CAN BE LOOSENED TO ALLOW WINDING OF THE SPRING. MAKE SURE YOU RE-TIGHTEN THE SET SCREWS BEFORE LOOSENING GRIP ON THE BARS AS THEY WILL BE UNDER SPRING PRESSURE AND MAY CAUSE INJURY.

#### STEP - 2.

- WITH ADJUSTING BARS INSERTED AND SET SCREW LOOSENED, TURN CONE IN THE SAME DIRECTION THE DOOR CABLE PASSES OVER THE PULLY TO INCREASE OPENING FORCE.
- TO DECREASE THE OPENING FORCE, TURN THE CONE IN THE OPPOSITE DIRECTION. REMEMBER TO TIGHTEN THE SET SCREW BEFORE REMOVING ADJUSTING BARS!
- MAKE ADJUSTMENTS IN SMALL INCREMENTS (MAX.  $\frac{1}{4}$  TURN). BALANCE SPRINGS BY TURNING THEM THE SAME AMOUNT.
- AFTER EACH ADJUSTMENT, TEST BALANCE BY CAREFULLY UN-CLAMPING DOOR AND RAISING DOOR.

**HERCULES**  
**COLD STORAGE DOORS**  
**INSTALLATION INSTRUCTIONS**

DRAWN BY: DSD      DATE: 6/16/09

**3.1 ELECTRICAL CONNECTIONS-DOOR JUNCTION BOX**

**IMPORTANT:** All electrical work must be performed by a licensed electrician. All electrical work must conform to the National Electric Code as well as any state or local requirements.

**IMPORTANT:** Tous les travaux d'électricité doivent être faits par un électricien qualifié. Tous les travaux d'électricités doivent être faites aux normes du code du bâtiment et locale.

Heater(s) must connect to branch circuit overcurrent device of 15 amps.

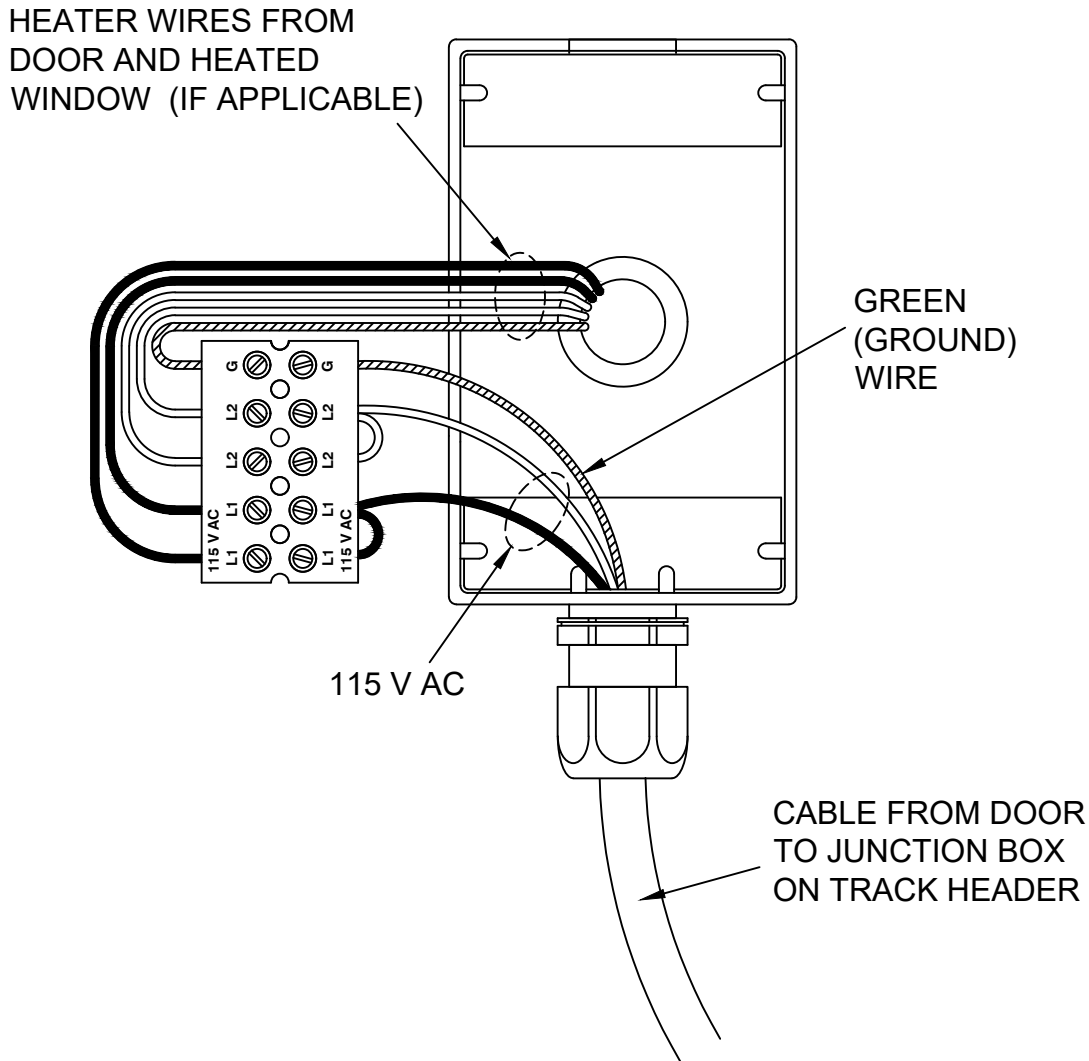

**FREEZER APPLICATION**

### **3.2 ELECTRICAL CONNECTIONS - ELECTRIC OPERATOR**

MOUNT THE ELECTRIC OPERATOR PER INSTRUCTIONS WITH THE OPERATOR. ALSO MOUNT ELECTRIC EYE SENSORS AT BOTTOM OF DOORS AND RUN WIRING TO THE ELECTRIC OPERATOR PER INSTRUCTION GIVEN WITH THE ELECTRIC OPERATOR AND THE ELECTRIC EYE SENSORS.

**IMPORTANT:** All electrical work must be performed by a licensed electrician. All electrical work must conform to the National Electric Code as well as any state or local requirements.

**IMPORTANT:** Tous les travaux d'électricité doivent être faits par un électricien qualifié. Tous les travaux d'électricités doivent être faites aux normes du code du bâtiment et locale.

### **4.1 Final Adjustments & Clean-up**

After installation has been completed and tested for proper operation, cut all carriage bolts flush with the nuts and install the supplied nut caps shown below.

